

YOUR PARTNER FOR CUSTODY TRANSFER MEASUREMENT



Eximp International specializes in offering complete turnkey metering systems for liquid & gas custody transfer applications using state-of-the-art measurement technologies



Offshore | Onshore | Upstream | Midstream | Downstream



ENGINEERING EXCELLENCE IN MEASUREMENT PACKAGES

8926 N. Greenwood Ave #221, Niles, IL 60714 USA.
Tel- +1 847 779 4603, Fax- +1 847 655 2847,
Email: projects@eximpintl.com

ABOUT US

YOUR PARTNER FOR CUSTODY MEASUREMENT

Eximp International is a global solution provider in the design, manufacture and supply of custody transfer measurement products and allocation metering skids for the oil and gas industry worldwide.



With 100 years of combined measurement experience, 100+ successful projects and over 70+ satisfied customers, we have mastered the art of building lasting relationships with our customers by providing untechnical solutions.



Eximp International delivers products with accurate performance in some of the world's most challenging & harsh environment all the while providing unrelenting quality. To ensure high-quality standards and prompt delivery, all supply phases of our measurement solutions, products and/or packaged systems are controlled by a comprehensive quality program. Eximp International is a "One Stop Shop" for reliable measurement needs in the hydrocarbon industry. Our solutions can be found at each stage of the upstream production onshore/ offshore, midstream processing & transportation and downstream refining or delivery for both liquid and gas petroleum products.

Once we work together to determine the right technology fit for the end user then Eximp International can work towards offering you a complete solution meeting the current industry standard and certifications. Our liquid & gas metering systems include turbine, Coriolis, ultrasonic, PD, Orifice, Cone, Venturi and proving systems using Uni/bi-directional provers, compact small volume provers, master meters, portable provers and water draw calibration systems

No metering is complete without a comprehensive qualitative analytical system. Whether it is a high accuracy water cut or density measurement for liquids using in line densitometers, viscometers or an online Gas Chromatograph, Moisture, H₂S or Hydrocarbon Dewpoint analyzer for gas calorific measurement, Eximp International can provide you a complete integrated solution complete with a reliable and dependable filtration and sample conditioning & pressure reducing system fully integrated with redundant fiscal flow computation to deliver a seamless quantitative and qualitative measurement.

Metering control & computing systems are the backbone of accurate fiscal metering. Eximp International designed fiscal flow computer systems & panels can easily interface to any 3rd party supervisory, SCADA system, or PLCs and upgrade any legacy system while minimizing CAPEX/OPEX costs. Our field proven Metering Supervisory & Validation System helps provide a centralized overview of your overall station parameters and provides the critical inputs for operators to monitor and act on key areas to operate and maintain the system optimally at all times which is critical for fiscal measurements.



COMPANY VALUES



We value teamwork and assume collective responsibility, ownership and accountability for our actions.

Eximp International is a result-oriented organization where all the employees are dedicated to achieve a common goal i.e. customer satisfaction. Being creative enables to give more pragmatic solutions, thus making us by default customer favourite. We provide simple yet effective solutions to the most complicated solutions that arises in the oil & gas sector due to the experience of our engineers.

We strive to excel in every aspect of our business by collectively delivering quality services of unmatched value through simple, easy and relevant solutions. We value teamwork and assume collective responsibility, ownership and accountability for our actions. We understand the importance of our missions and the trust our customers place in us. We respect our team members, supplier partners and customers and recognize their contributions towards the growth of our company.

At Eximp International, we emphasize on the value of teamwork and encourage our staff to work as a team to maximize their effectiveness. Our friendly approach is built on a positive attitude thus encouraging customers and colleagues to try new solution and technologies. We deliver our very best and hold ourselves accountable for the results.

Our core values shape the culture and define the character of our company. They serve as a foundation for how we act and make decisions. Our company's commitment to our core values and ethical conduct is important, but the personal commitment of every employee is critical to make this commitment effective. By acting consistently as per our core values, we can each do our part to assure that Eximp International earns its reputation as a company which conducts its business with the utmost integrity, accountability and excellence.

Integrity

We are committed to the highest standards of ethical conduct. We believe that honesty and integrity engender trust, which is the cornerstone of our business

Ownership

We all act like owners treating the Company's assets as our own and behaving with the Company's long-term success in mind

Perform With Excellence

We understand the importance of our missions and the trust our customers place in us. With this in mind, we strive to excel in every aspect of our business and approach every challenge with a determination to succeed

Respect Others

We recognize that our success as an enterprise depends on the talent, skills and expertise of our people and our ability to function as a tightly integrated team. We appreciate our diversity and believe that respect is an positive and productive business relationships

Accountability

We take full responsibility for our work and try to achieve the desired results thus ensuring high performance within our organization. We accept personal accountability to meet the business needs, improve our systems and help others improve their effectiveness

Reliable and Trustworthy Business

We believe that people work best when there is a Being Reliable provide us the freedom to expand our operations around the world and generate new business opportunities, differentiating us from our competitors



EXIMP INTERNATIONAL CAPABILITIES



PROJECT: MEHAR GAS FIELD INTEGRATION PIPELINE

12" 600RJ Skid Mounted Orifice Metering System complete with field instruments, Gas Analyzers, Field flow computer
Design: 1 x 100% with bypass
Process: Flow 50MMCFD
Pressure: 500-1200psig



PROJECT: SULEMAN GAS FIELD

6" 900RJ Skid Mounted Orifice Metering System Complete With Field Instruments, Gas Analyzers, Field Mount Flow Computer, Chart Recorder
Process: Flow 10-35 MMSCFD
Pressure: 1000-1600 Psig
System Design: 1 x 100% without Bypass



PROJECT: RLNG TERMINAL KARACHI

16" 600RJ Skid Mounted Multipath Ultrasonic Skid Complete with Field Instruments, Gas Analyzers & Shelter, Panel Mount Flow Computers, SCADA/HMI, Rack Mounted Server, UPS with Solar Back Up
Process: Flow 100-400 MMSCFD
Pressure: 900-1200 Psig
System Design: 2 x 50% with Bypass & Master/ Check Meter



PROJECT: RLNG - PAKLAND- KHADEJI INTERLINK

16" 600RJ Skid Mounted Orifice Metering Skid Complete with Field Instruments, Gas Analyzers & Shelter, Panel Mount Flow Computers, SCADA/HMI, Rack Mounted Server, UPS with Solar Back Up, Validation Systems.
Process: Flow 400 MMSCFD
Pressure: 1000-1200 Psig.
System Design: 2 x 50% with Bypass



PROJECT: JHAL MAGSI GAS FIELD INTEGRATION PIPELINE

6" 600RJ Skid Mounted Orifice Metering Skid Complete with Field Instruments, Gas Analyzers, Analyzer Shelter, Field Mount Flow Computers, Sample Conditioning, Validation System
Process: Flow 05-20 MMSCFD
Pressure: 500-1200 Psig.
System Design: 1 x 100% with Bypass
Inlet/Outlet: 8", FE, CL.600 RJ



PROJECT: RLNG 2 PIPELINE

20" 600RJ Skid Mounted Multipath Ultrasonic Skid Complete with Field Instruments, Gas Analyzers & Shelter, Panel Mount Flow Computers, SCADA/HMI, Rack Mounted Server, UPS with Solar Back Up
Process: Flow 1200 MMSCFD
Pressure: 900-1200 Psig.
System Design: 2 x 50% with Bypass & Master/ Check Meter



***“ Our company is the presentation
of our capabilities ”***

AltaGas



Imperial Oil



Canadian Natural

Atlantic



ConocoPhillips
Canada 

PETRONAS



PERTAMINA GAS

ExxonMobil

YOKOGAWA



PennWest
Exploration

Anadarko
Petroleum Corporation 



PETROBRAS

encana™

Chesapeake
ENERGY



devon

British Gas

nexen

SSGC

PEMEX



EXPRO

SINOPEC

OFFSHORE



MODEC

LOCAL LEADERSHIP IN GLOBAL ERA



We draw on our extensive expertise to provide global metering support. To date we have provided +100 metering services across Europe, USA and Canada, South America and West Africa, as well as in the Middle East and South-East Asia. The approach to the client problems, allowed Eximp International to expand its supply of services, in the fields of interest, on the domestic and worldwide markets with private groups and well-known International companies.

With over two decades' experience in the Oil and Gas Industry, Eximp International offers its clients an unsurpassed understanding of the fabrication and construction. Eximp International continues to expand its horizon in the oil and gas industry by ensuring that our meters, meter provers, flow computers, instruments, samplers, and all other elements comprising the measurement system operate effectively to deliver the information required for overall measurement integrity.

In two decades the company has grown to national and international prominence. Eximp International has built many successful projects, established exceptional reputation for craftsmanship and integrity. Today these strengths make the company uniquely qualified to meet client's requirement.

GLOBAL OUTLOOK

At Eximp International, solving our customer's challenges is our priority. Eximp International's technology competence and global presence offers customers easy access to leading oil and gas industries. Understanding and providing global support is a key part of Eximp International's business. Today, Eximp International has a strong presence in over 15 locations, spread across the United States, Canada, Mexico, the Middle East and India South Asia.

LOCAL REACH

Providing local support is one of the reasons behind Eximp International's success. We are global in our outlook but local in our reach- with local offices in every region catering to specific local requirement. The solutions provided help customers to increase the productivity of their assets and boost quality while saving energy.





LIQUID AND GAS METERING SKIDS

A Metering Control System is primarily responsible for transforming the available accurate field data in valuable information which ultimately leads to strategic decisions for operation and maintenance of the metering system. Online validation and other forms of Performance Monitoring contribute in lower overall uncertainty and higher reliability of your metering applications.

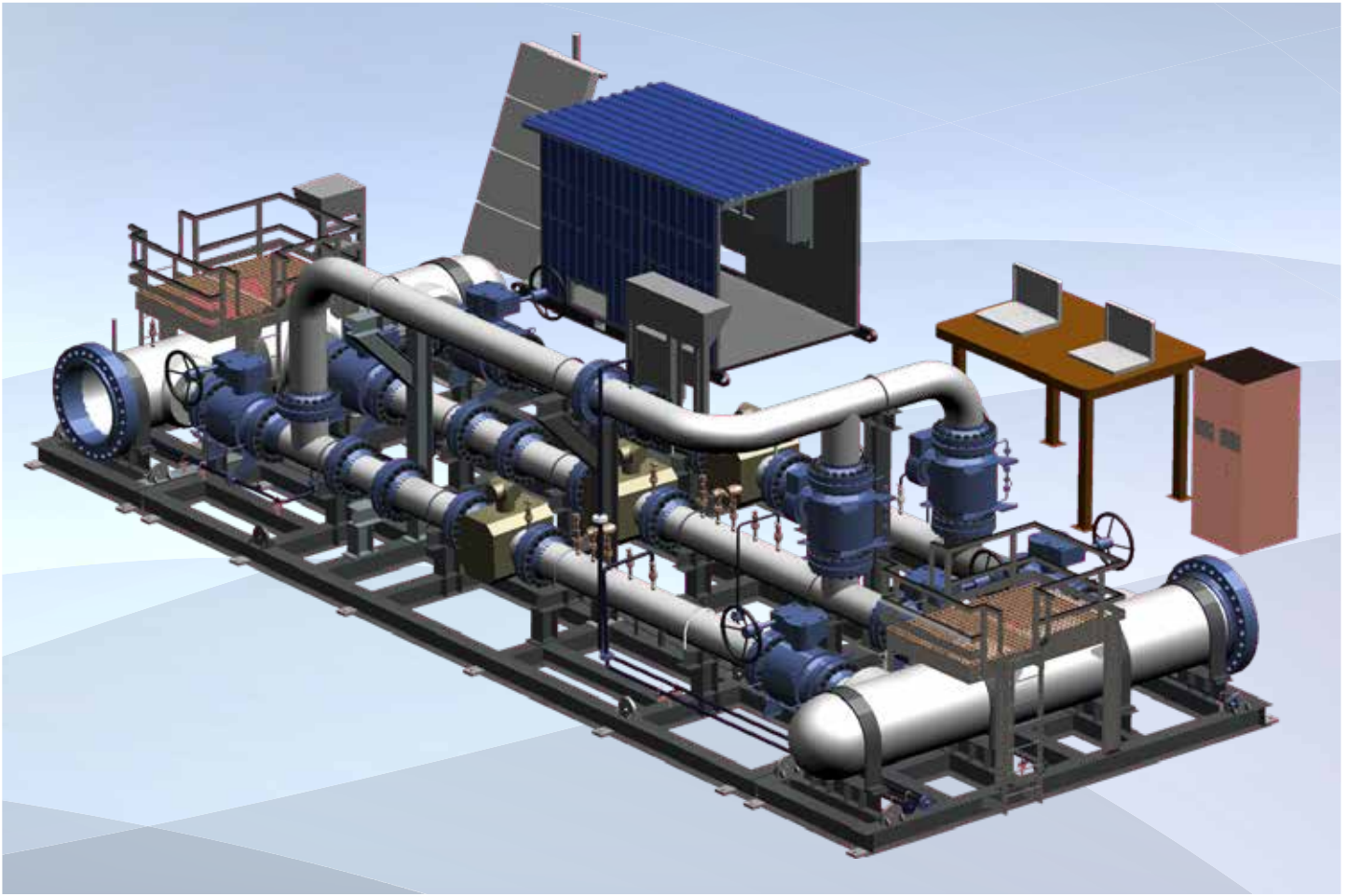

Eximp International is specialized in providing a complete package for complete Metering system with an engineering solution for design, construction and commissioning of field-proven innovative solutions for Custody Transfer Flow Measurement in the worldwide Oil & Gas Industry.

Eximp International has the capability to deliver a reliable and accurate metering solutions with a diversity ranging from high viscosity liquids to natural gas to cryogenic liquids. Our experienced team with high level understanding of measurement standard and competency in engineering and integration is able to deliver all type of master, check, allocation metering, proving and validation systems that ensure lowest measurement uncertainty and highest measurement reliability and confidence at all times.

A Metering Control System is primarily responsible for transforming the available accurate field data in valuable information which ultimately leads to strategic decisions for operation and maintenance of the metering system. Online validation and other forms of

Performance Monitoring contribute in lower overall uncertainty and higher reliability of your metering applications.

A typical liquid custody transfer metering skid includes multiple flowmeters and meter provers. Provers are used to calibrate meters in-situ. Proves are performed frequently, typically before, during, and after a batch transfer for metering assurance. Eximp International's Custody transfer metering systems meets requirements set by industry bodies such as AGA, API, or ISO, and national metrology standards such as OIML (International), NIST (U.S.), PTB (Germany), CMC (China), and GOST (Russia), among others.

The purpose of our systems is to precisely and repeatedly measure the flow of hydrocarbons in accordance with OIML R117 international recommendations, OSI and API standards. The implementation of a measurement system for custody transfer provides benefits from the first day of operation as it ensures maximum reliability of the measured product, reducing the number of losses due to unreliable measurements or a lack of measurements.

Eximp International engineers have built hundreds of meter skid configurations for customers in the oil refinery, petrochemicals and natural gas industries, and each design undergoes through performance and safety testing before arriving at your site or facility. It's our goal to provide you and your crew with high quality, competitively priced fluid packaging solutions, and we also offer a variety of installation and services.

By using proven industrial components and flexible software platforms for our Metering Control Systems, we ensure optimum maintainability and upgradeability. Together with Remote Diagnosis and Condition Based Maintenance, the metering systems will reduce your operational cost and ensure availability of your precious metering data and equipment. Making use of the latest development of electronic field instruments, our Metering Control Systems are often supplied with Condition Based Maintenance to utilize real-time data to prioritize and optimize maintenance resources.

GAS QUALITY AND CONTROL

Like quantity, the quality of the fluid (especially in hydrocarbons) is of equal importance when it comes to determining its fiscal value. Eximp International offer full custody transfer metering package including Sampling and Analyzer systems.

”

Eximp International's real time gas analysis enhances the safety, performance, quality of the product; all along maintaining proper environmental standards.





Eximp International helps you maintain correct quality control. Our products include sampling system and analyzer to measure pH, density, conductivity and turbidity; gas chromatographs; mass spectrometers; FTIR spectrometers; photometers (IR and UV); and physical property analyzers. From high quality portable field to stand alone measurement instruments and system, Eximp International offers you end to end solutions that will help you monitor, protect and control your critical processes and applications.

At Eximp International, we offer a full range of services to suit your gas requirement needs. Our aim is to provide with an expert and efficient service to ensure the safety and protection of our customers.

No metering is complete without a comprehensive qualitative analytical system. Whether it is a high accuracy water cut or density measurement for liquids using in line densitometers, viscometers or an online Gas Chromatograph, Moisture, H₂S or Hydrocarbon Dewpoint analyzer for gas calorific measurement, Eximp International can provide you a complete integrated solution complete with a reliable and dependable filtration and sample conditioning & pressure reducing system fully integrated with redundant fiscal flow computation to deliver a seamless quantitative and qualitative measurement.

Eximp International's hygrometers are a state-of-the-art option for measuring dew points of water and hydrocarbons. Analyzers are designed for taking high-precision and rapid measurements and can be used in explosion hazardous zones. We provide detectors of different design and types to measure natural gas humidity.

Humidity measurements can imply various difficulties at phases of natural gas production, treatment and transportation. Therefore, Eximp International meets each challenge by providing the best solution with the help of additional equipment and devices to deliver and filter gas samples or heat sampling lines and all elements of the gas purification system.

VALIDATION SYSTEMS

Every Oil and Gas company's major challenge lies in verifying and calibrating their meter systems, in order to ensure long term health of the tubes, reduce inaccuracies, and improve performance. Because even the slightest error in calculation, can amount to big losses for the company.

But if we're verifying meters the traditional way, by removing and hauling them to a lab, the production process will be interrupted. Removal and reinstallation hassles, re-approvals processes are time-consuming, and perfectly good metering systems could get damaged during transport.

The whole process is costly, time-consuming, highly unproductive and highly unnecessary, especially if the meters turn out to be working properly.

So how can we guarantee meter accuracy, while minimizing effort and time spent?

- How can we reduce inaccuracies to %0.01 or less?

Reduce the money spent on testing and calibrating, and yet, test and calibrate the metering systems effectively?

By offering real time validation of DP based flow meters, we help you check the meter health, flow tube integrity and performance of your systems, without losing valuable production time.

Our cutting-edge validation system allows you to run validation tests from anywhere, at any time, in real-time.

You can also run calibration tests as often as your auditing process demands, without spending an extra time.

Proving and Validation is where Eximp International stands out from the rest.

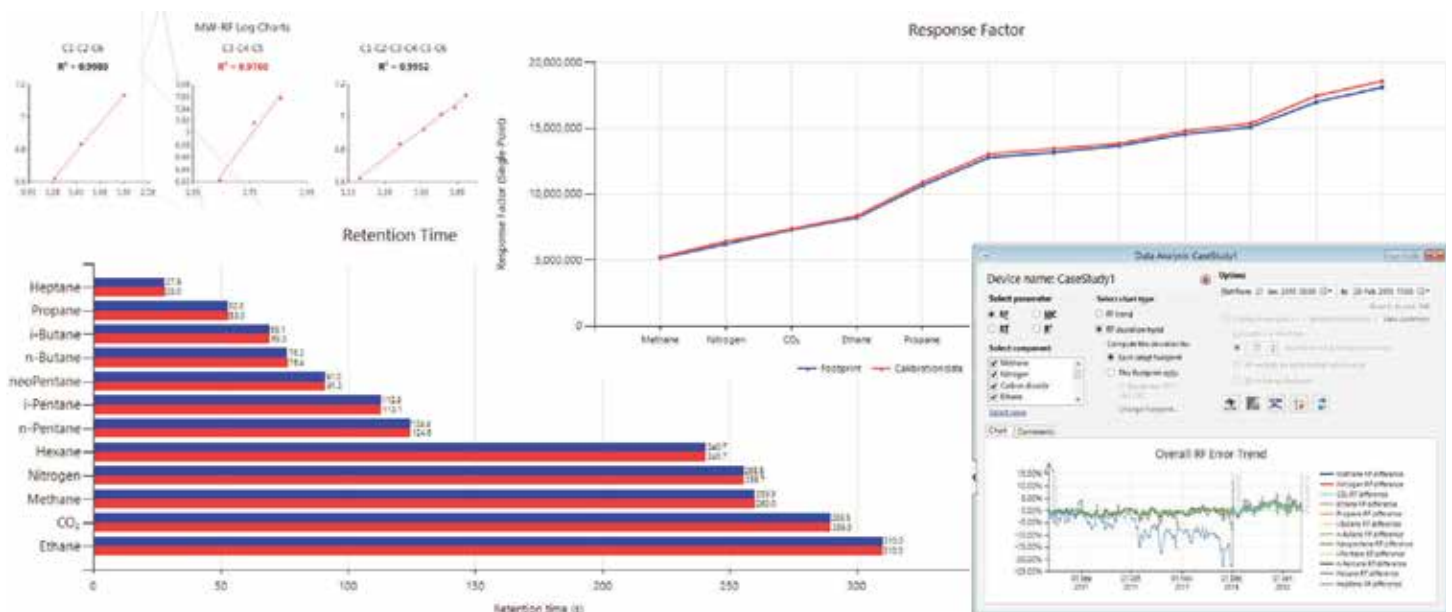



TEKVALSY GC

Eximp International offers TekValSys GC, a unique condition based monitoring (CBM) software package for Gas Chromatographs providing live uncertainty calculations based on routine gas calibrations.



What is Live Uncertainty?

With its unique method for analyzing reproducibility, TekValSys GC is able to give you live uncertainty calculations after routine calibrations. Until recently this could only be achieved with laboratory analysis. For scale applications TekValSys GC can apply these values to ISO6976, to routinely calculate representative uncertainties for Caloric Value, Molecular Weight, Wobbe Index, Relative and Standard Density. TekValSys GC can be installed by the end user and doesn't require you to call out a GC specialist. TekValSys GC is a Windows application and is therefore compatible with most standard desktop and laptop PCs.

What Can TekValSys GC Detect?

TekValSys GC validates the gas chromatograph's performance by detecting:

- Calibration Gas Errors
- Gas Chromatograph Leakage
- Column Deterioration
- Valve Timing Issues
- Poor Handling Procedure
- Heavy End Drop Out
- Fault in Repeatability Test Interpretation
- Fault in Control Chart Interpretation
- Fault in Composition Comparison

What is TekValSys GC?

A unique and comprehensive Condition Based validation software package for Gas Chromatographs (GCs), comprising of GCAS software and Panel PC for hazardous or safe areas. As an automated condition based monitoring software TekValSys GC:

- Provides real time assurance that the GC is operating correctly
- Analyses historical data to identify changes and predict future failures
- Reduces the need for conventional maintenance and unnecessary costs
- Determines dynamic GC uncertainty for quantification of GC performance
- Validates that the pressure let down system provides a representative sample
- Creates a fully auditable database of GC performance
- Helps to support and increase a technician's competence level.



TEKVALSYS DP

The TekValSys DP comprises of Condition based monitoring software Prognosis on panel mount or portable computer along with sensors for measuring recovered DP and Permanent Pressure Loss DP. This is available for hazardous as well as safe area.

This patented technique has proven to be an extremely powerful tool in ensuring accuracy, providing real time alerts of meter mismeasurement and performance shift and reducing maintenance overheads on DP systems.

Applicable to all types of differential pressure metering systems including Orifice, Venturi, Cone, Flow Nozzle and Wedge, TekValSys DP uses three Differential Pressure (DP) measurements to monitor the entire pressure through the meter body.

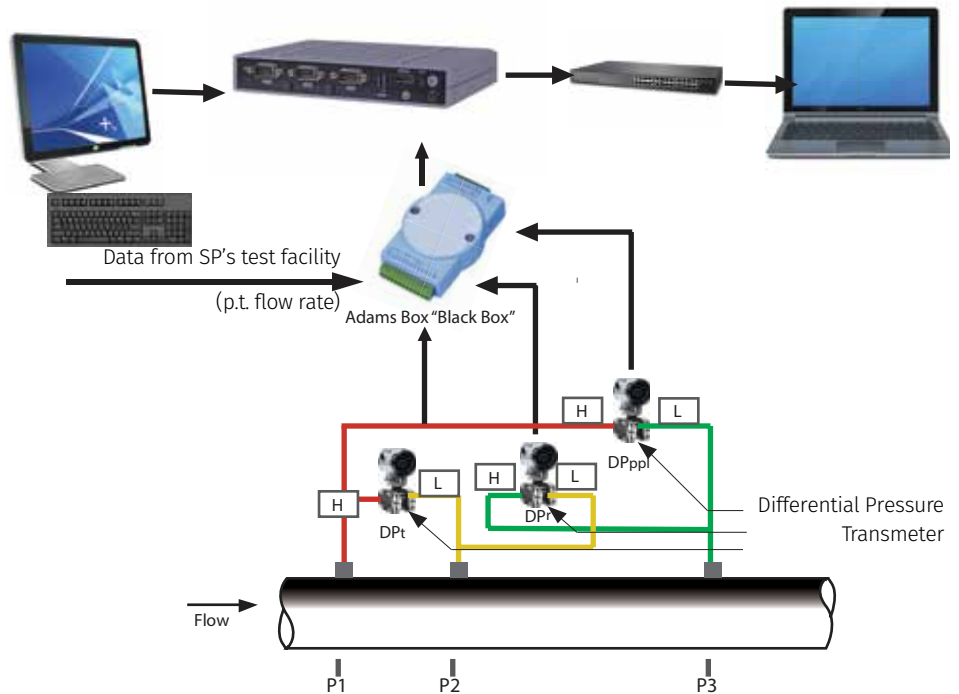

Features:

- Improve safety
- Minimize maintenance
- Avoid down-time
- Huge cost saving

Various comparisons are made, constantly comparing actual meter performance with expected meter performance producing four pairs of normalised diagnostic results.

The results are very simply presented as four points on a x,y axis. A 1x1 the allowable variance of the meter performance.

All points inside the 1x1 box indicates good meter performance (each comparison result is within its allowable uncertainty).

Any point outside of the box means that actual meter performance is not agreeing with expected and there is potentially a non-compliance or a fault, producing an error in meter flow-rate prediction.

Pattern of diagnostic results provides indication of cause of alarm which is displayed in real-time on the software User Interface and output as an Alarm value.

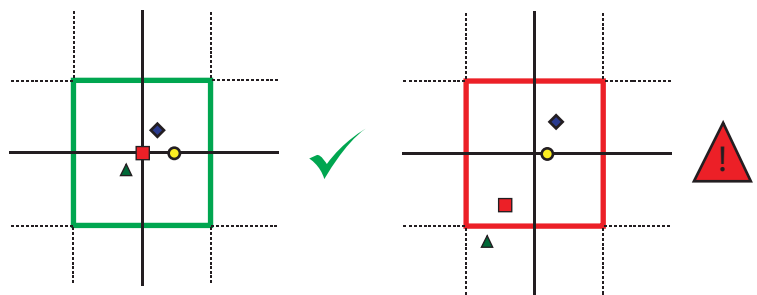
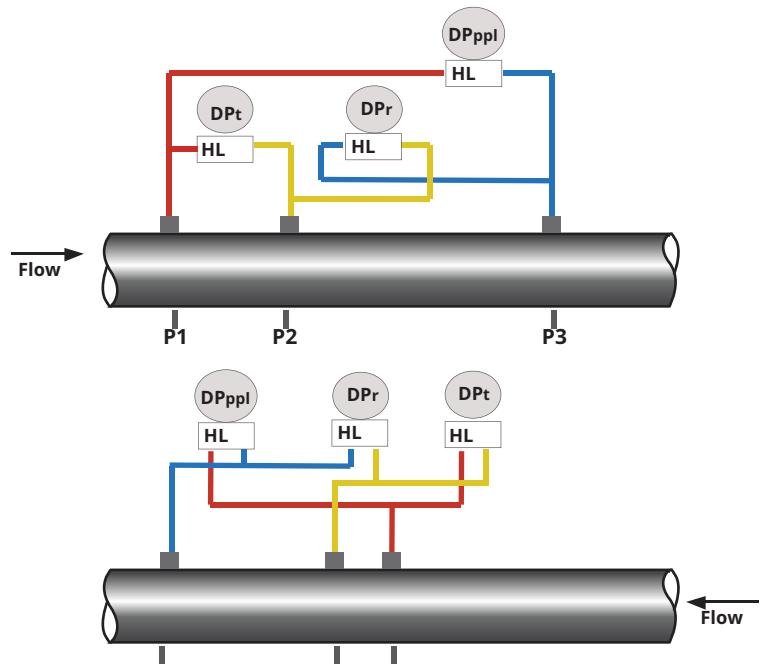



Reduced Financial Exposure to Mismeasurements

- Real-time alerts of non-compliance and significant measurement bias
- Avoid mismeasurement disputes and damaged reputation
- Distinguish error or drift in DP transmitter readings from meter system issues



Reduced Maintenance Costs

- Condition-based monitoring allows condition-based maintenance
- Reduced maintenance regime due to condition based responses



Reduced Risk to Personnel Health and Safety

- Avoid requirement to break hydrocarbon containment
- Avoid maintenance-induced errors or incidents.
- Reduce trips to remote and hazardous locations.
- Improve H&S record



Assurance of Meter System Performance

- Improved assurance of system metering accuracy.
- Definitive confidence in meter results.
- Real time and historical proof of meter performance.



Financial Payback could be achieved in a matter of days

- TekValSys DP will distinguish between a secondary instrumentation issue and a primary meter body-based physical problem avoiding unnecessary inspection and down time.

SHARING MEASUREMENT BEST PRACTICES

“People at Eximp International are completely focused to achieve a common objective and that’s why we recruit people who has passion to achieve something bigger and something much more important that shapes the company’s future and drives it forward.”

At Eximp International, we’re constantly in quest of perfection. To ensure maximum profitability, we consistently share best practices with our customers and distributors.

Eximp International offers comprehensive training programs specifically developed to impart valuable practical skills that will result in improved performance, safety, energy efficiency and optimized costs, all focused around emerging needs. Our programs are highly flexible; and can be adapted to every customer’s specific objectives, time constraints and skill level. The training programs can be conducted at our customer’s project sites or at our facility across globe. The trainings are not only for the customers but for employees as well. Our company focuses on the well-being of our employees by ensuring the growth of the employee.

We also conduct metering system audits, and offer metering consultancy services and training for operators & engineers customized for their needs. Our consultancy services include independent metering expertise for natural gas measurement, LNG, hydrocarbon allocation for production and transportation, multiphase metering, and metering for environmental compliance including emissions and pollution related legislation.



QUALITY ASSURANCE

BEST PRACTICE

Throughout the process, we keep a strict eye on our Health, Safety and Environmental standards, making sure we comply with global best practices and regulations.

We place great emphasis on creating a safe and hazard-free working environment, while putting in place policies that prevent pollution in any form, as a result of the design, manufacturing or operation of our systems. We also adhere to all environmental and legal regulations applicable in the regions we operate in.

Eximp International regularly conducts training and awareness camps for our employees, in a bid to prevent accidents and injuries. Apart from a strong focus on HSE standards, Eximp International seeks continuous improvement in the effectiveness of its products, services and processes through the implementation of our quality assurance policy. As part of this policy, our delivery processes are constantly evaluated and improved in light of their efficiency, effectiveness and flexibility.



BEST PROCESS

Eximp International continuously strives to implement processes throughout the organization and aims for continuous improvements of its effectiveness in accordance with the requirements its quality assurance policy. These continuous improvements are ongoing efforts to improve products, services or processes.

These efforts can seek “incremental” improvement over time or “breakthrough” improvement all at once. Delivery (customer valued) processes are constantly evaluated and improved in light of their efficiency, effectiveness and flexibility.



PRODUCT PARTNERSHIPS

Partnerships are an important part in today's Market Development Strategies. We understand the importance of a partnership and value our partners thus enabling to integrate our value chain to create a whole new product solution.

We work alongside our partners in the Oil and Gas sector, at all levels of the organization, to advise on the risks and opportunities inherent in their business and to implement solutions that produce sustained and lasting results for our business partners.

We continue to work on introducing newer technologies together with our strategic partners to make fiscal measurement more accurate, affordable and easy to use.



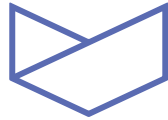

VYMPPEL

Vympel hygrometers are a state-of-the-art option for measuring dew points of water and hydrocarbons. Vympel offers Portable and Automatic Hygrometer Analyzers, designed to take high-precision and rapid measurements and can be used in hazardous explosion zones. There are over 2000 SPA Vympel dew point analyzers installed and in use worldwide, which makes Vympel a gold standard in natural gas hygrometry.



PIPELINE EQUIPMENT

RMA Measuring and Control Technology has evolved over the years as a leading manufacturer of Gas Ultrasonic flowmeters at their German facility and sold successfully worldwide. RMA also operates their own high-pressure gas calibration facility and caters to customer and OEM looking for an state approved calibration facility.





Established in 2003, TMCO is a leader in the design and manufacture of orifice fittings for the measurement of gas in energy and process control industries in India. With input from engineering firms, measurement specialists, and field personnel, TMCO has strengthened the advantages of orifice metering by implementing features that improve the performance of your meter runs, simplify your operations, reduce maintenance costs and keep your people safe in the field.

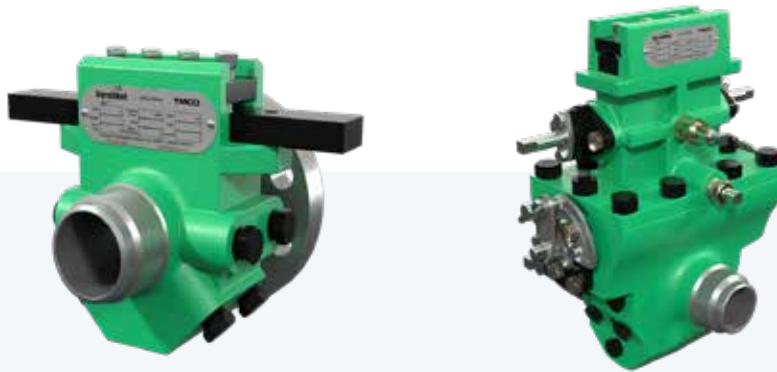

A Technology-driven company that believes in providing specialize solution and analyzer to enhance the operational performance.





Providing cutting edge tek-nology for flow, level, temperature and pressure measuring instruments, Analyzers and specialty Valves

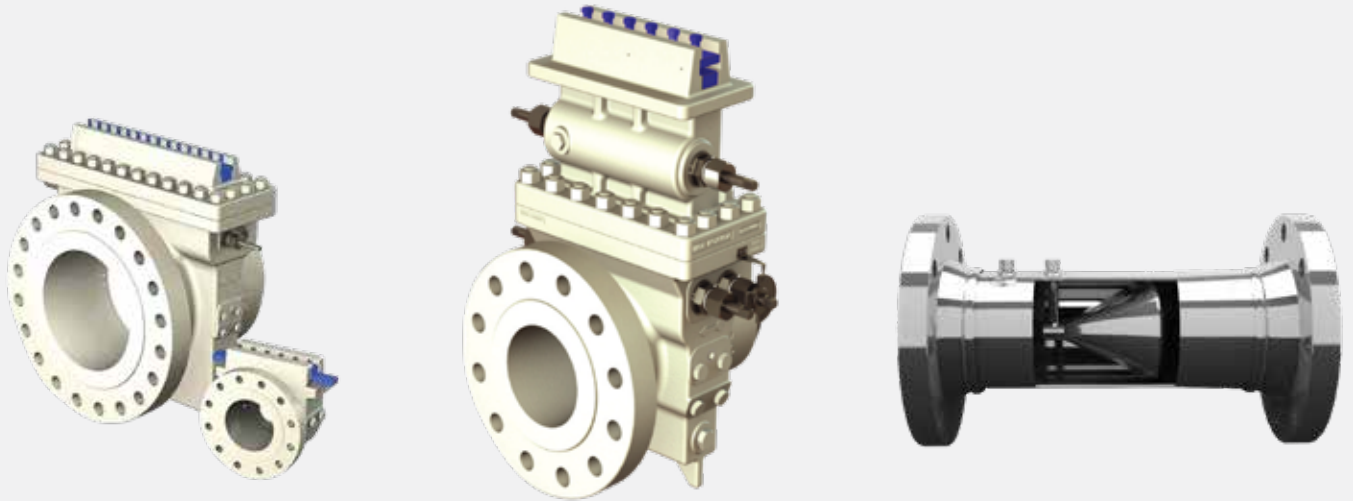



FIELD SERVICE AND SUPPORT

“ Good Service Makes The Difference ”

At Eximp International, our relationship with the customer goes beyond the sale of products. Eximp International is an integrated engineering consulting service, serving across all industries and geographies in line with the dynamic nature of its clients' requirements. Our personnel are experienced specialists who focus on the client's requirement and provides in-depth project development and leadership services in every sector.

Being a solution driven company, we focus solely on providing solution that leads to enhancing process performance and reducing costs for the entire operational process, right from production through logistics.

Our field service and support includes:

- On-site diagnostics and calibration
- Preset and flow computer programming
- On-site training for meter technicians, operators, operational assistance
- 7/24 on-call or on-line technical support via phone, fax, email or internet for long distance equipment diagnostics

Eximp International provides Engineering services in the fields of Oil and Gas, Chemical, Petrochemical, Water and Wastewater, Marine, Steel, Food and Beverages, Pharmaceutical and Paper.

WE PARTNER, ADVISE, CONSULT AND ASSIST OUR CLIENTS IN:

- Identifying business opportunities in line with our principals, business partners, strategic associates, resources and capabilities
- Provide market intelligence to our principals, business partners and strategic associations in accordance with their specific business interests and needs
- Co-ordinating preparation of bid and contract documents
- Undertake feasibility studies, and project risk assessments
- Selecting and engaging the right contracting team model
- Optimizing the business parameters of the project concept design

- Providing expert commissioning program development, program management, and complete plant start up services
- Providing construction management services including packaging, scheduling and monitoring construction activities
- Facilitating project start-ups
- Coordinating government submissions and approvals
- Coordinating the design development on behalf of the client
- Developing project strategy
- Choosing the optimum project delivery system and contract
- Providing all the resources necessary to successfully commission, manage, operate, maintain, and administer the business and technical operation of the facility
- Providing contract administration services





**8926 N. Greenwood Ave #221,
Niles, IL 60714 USA.
Tel- +1 847 779 4603,
Fax- +1 847 655 2847,
Email: projects@eximpintl.com**